

Falco Builders Letter



Climbing aboard in Biella, Italy.

Lightness in Air

In the sunshine above the clouds and at the mercy of the Atlantic

by Andrea Tremolada

On June 26, Andrea Tremolada left Biella, Italy for Seville, Spain and the first leg of his flight across the Atlantic. The next leg was from Seville to Sal Island, Capo Verde, off the coast of Senegal in West Africa. With full fuel, the Falco was very difficult to fly for the first two hours, but flight conditions were good with no wind and a hazy sky. In all, it took 12 hours and 5 minutes, and Andrea landed tired and happy.

And on Monday, July 3, while America tanned at the beach and shopped for fireworks, Andrea Tremolada took off from Sal Island for the longest and most harrowing flight of his life. Here is Andrea's account, and we join him at Sal Island.—Alfred Scott

A week after departure from Biella, the international airport of Amilcar Cabral is the last outpost before the great stretch of ocean. It's five in the morning, and this time there are no friends gathered to see me off.

I sort out the last bits of red tape, fill the tanks and drop by the desk at the meteorological



Andrea preparing to leave Seville, Spain.

logical office. The charts show a disturbance arriving from Africa: I'm hoping to outrun it. Out on the vastness of the apron, under the leaden sky, the Falco seems to be even smaller than it really is.

I wonder just how small I am, too. How small is a man compared to an international runway? Compared to the incredible breadth of the ocean? And how great is the strength generated by the desire to achieve, to fulfil a dream?

Great enough, in my case, to take a bull-headed run at the problems I'd met so far. Great enough to overcome the resistance of all those who insisted that I'd fall asleep after 12 hours of uninterrupted flying.

In This Issue:

- 6 The Glider, Part 18
- 8 From Perugia to Oshkosh
- 12 Construction Notes
- 13 Sawdust
- 13 Goings On at Sequoia
- 13 Susan's Corner
- 13 Calendar of Events
- 14 Mailbox

I slowly do up my seat-belt. Before I take off, I remain silent, listening attentively. What if I were biting off more than I could chew? What problems might I run up against during the flight? Little by little the sky begins to brighten with the first light of dawn. Drops of rain are falling, soaking the cockpit, the flight charts and my hair. I insert the ignition key, the propeller turns over three times and the engine comes to life. The fuselage shakes and the maps flutter about crazily.

We're off. My hands hurry to key in the frequencies, regulate the altimeter, set the engine. My brain switches to autopilot, there's no room for emotions—I'm straining to pick up any unusual sound. Everything's working perfectly, everything's normal. The plane shudders, the brakes can no longer hold it back—it wants to be free, ready for the transatlantic leap. I'm worried, though. I watch the sky. I cross myself and touch the Madonna di Loreto key-ring, a gift from the priest who had blessed the plane on Friday before the start of the journey.

As I pick up speed, the wings begin to take the weight off the undercarriage. As usual, my little plane flies badly at first, but she's more at home in the sky than on the



Andrea over the Atlantic. Ignorance of the weather ahead is bliss.

ground. After about three minutes I make a slow turn to port, as the first wisps of vapour begin to caress the fuselage. A couple more seconds and I'm wrapped in the darkness of the cloud.

As I break out into the sunlight at 4,000 feet about fifteen minutes later, I recall what I used to say when, during the grey days of a Milan winter, my friends

would complain of the rain. I reminded them that above the clouds there was bright sunlight. Always, despite the gloom. But isn't life like that, too? There are times when everything seems to fall on your shoulders, and others when we smile and seem to be walking in the sunlight, overcoming with ease all the obstacles that life puts in our path every day.

It is some time since the sea has been visible. Here, 500 miles after takeoff the weather I had seen on the charts announces itself. The plane trembles and shakes. The warmth of the cockpit is all I have to reassure me. I take off the headphones and listen to the terrifying noise. The plane's wooden framework transmits every vibration, amplifies it like a sound chamber. I check my position on the maps. I run up against the first problems at 9:14, 504 miles from takeoff. That's about when I enter the turbulence and begin to



The Falco Builders Letter is published 4 times a year by Sequoia Aircraft Corporation, 2000 Tomlynn Street, Richmond, Virginia 23230. Telephone: (804) 353-1713. Fax: (804) 359-2618. E-mail: support@seqair.com. Publication dates are the 10th of March, June, September and December.

Subscriptions: \$16.00 a year, \$20.00 overseas. Available only to Falco builders and Frati airplane owners.

Articles, news items and tips are welcome and should be submitted at least 10 days prior to publication date.



Preparing the Falco in Italy.

be tossed about. I've already banged my head several times against the canopy, and I've been hit many times by objects lying around the cabin. At 9:23, I enter a weather cell bigger than the others.

Darkness envelops the plane without warning and my speed drops rapidly. The hailstones are battering the fuselage. The GPS box hurtles towards me. I try to avoid it, but it hits me under the eye. I'm flying upside down. I only manage to work this out by looking at the Madonna on the key ring, no longer hanging towards my legs, but swinging head-down towards the instrument panel rim. Instinctively my left hand reaches out to touch it and beg for help. First of all I have to right the plane and re-establish the correct flight attitude.

I remember that it's clearer to starboard, so I make a 270 degree turn. Nothing, just more heavy water. But a few minutes later I re-emerge into clear skies, and I glance at the altimeter: I'm at 15,000 feet. I have a moment to pull myself together. A torrent of water has flowed in through the instrument panel, my shirt is soaked through, my trousers, hair and maps, too. All the breakers have tripped, there must be a short somewhere, and the best thing to do is wait. My father always used to tell me that

planes are the fastest means of transport for people who aren't in a hurry. And I shouldn't try to hurry things. I could turn back, stand once again on the Sal Island apron and wait for conditions to improve.

But the Atlantic is still the Atlantic, and the subtropical front is still in the same place. I'd have to get through it whatever happened, so I might as well do it now. I

reset the normal cruising conditions. I have to keep turning to avoid the blackest cells. I climb again.

At last, 150 miles on, I suddenly break out into blue skies. I cry tears of happiness. It's the first time since the flight began that I can see sea and sky at the same time. I hope that's it's really over, I grab my camera and take a few photos. I take a pee and





Andrea with the Italian Console in Seville.

have a bite to eat. I scan the sea, looking for a ship, but there are none to be seen.

I've been flying for seven hours.

I feel I belong more to the air than the earth. I'm part of infinite space, part of something bigger than anything I'd experienced so far. I feel light, and want to continue this flight without limits. I'm a dot on the ocean, but I exist. I'm moving at

150 knots, riding a dream unfolding moment by moment, slowly being burnt up like the fuel in the tank. I'd like to rewind time, relive every minute, even the journey through the storm—yes, even these moments play their part in the magical adventure. What makes us so happy when we live through something so magnificent? The uncertainty of what awaits us afterwards, or the desire to satisfy the perennial desire that pushes mankind forward?

Another disturbance sets in 450 miles from the Brazilian coast. I prepare once again for the airborne dance. Little by little the sky darkens. The turbulence gets worse, the rain becomes heavier. I turn 15 degrees to starboard, where I think I can see some chinks in the cloud.

My trousers are soaking wet: water is pouring in through the lateral intakes, sloshing over the fuel tank and ending up all over my legs. I feel like I'm standing in a car wash, but I don't find it funny.

I'd like a weather bulletin from Recife, but I can't get through to anyone on the radio. How far to Brazil? If all goes well, three and a half hours. No, it must be more. I can't follow a straight line, my course is made up of detours of fifteen or twenty miles to port or starboard to dodge the most threatening downpours.

My survival equipment includes a life jacket and a dinghy, but I'm not too sure how useful this will be, even if I manage to survive the impact of the plane as it hits the water. I'd have to unfasten my safety belt and throw that life raft into the water—I can't even stretch out my legs on it. They'd be dangling in the water, and in the cold of the night I don't think I would be able to survive.





At a reception in Seville with Spanish aeronautical authorities and the Italian Console.

Nature rebels with all its strength. The floor is awash. Here the raindrops aren't drops, they're pebbles. I'm cold, but the heating isn't working because I've had to close the outside air intake. It's dark now, and what little light there is in the cockpit comes from the glow of the two GPS units, greenish and reassuring.

I'm only 40 miles from the coast. I try to find Recife on the map in the flashlight's glare. I'm still too low, I must climb to 2,000 feet, the minimum height to intercept radio signals.

I thought things were bad at 400 feet, but at 2,000 it's an inferno. Bolts of lightning illuminate the sky as if it were day.

At last the control tower picks up my signal. I haven't spoken to anyone for 12 hours. One or two minutes and I identify myself, get instructions to continue. But the undercarriage doesn't respond—I have to lower it manually. I must watch out, to make a careless mistake now would really be a sick joke.

I look up, hoping to catch sight of lights. Still nothing. Then a freeway, then a little further on, the runway. We've made it. Brazil is passing below the belly of the plane.

I'm on land. I open the canopy and stretch out my arms. So what if it's pouring with rain, I want to have contact with the earth once again. I taxi to my parking spot, the man in front of me crosses his arms. This is the signal to turn off the engine. No, please, just one moment more. Under my belt now are 13 years of work, 13 hours and 43 minutes of flying.

In Milan, people are coming out of the

cinema or going to a club. In Brazil, a little airplane and her pilot complete the final few operations before finishing the long flight over the Atlantic. A crowd of inquisitive onlookers and photographers gather round my Falco. It takes me two tries to get out of my seat. I get down with difficulty. At last I'm touching the ground. The asphalt is soaking wet but pleasant on this cloudy evening. □



The Glider

Part 18 of a Series

by Dr. Ing. Stelio Frati
translated by Maurizio Branzanti

Center of Gravity Determined by Graphical Means. In order to determine the location of the center of gravity graphically, the polygon method is used. Using the side view of the aircraft, we draw vertical lines through the already pre-established partial center of gravities. These lines represent the direction of the weight-forces applied to them.

On one side, the *polygon of the forces* is constructed. All the individual weights are reported according to a selected scale and drawn one after the other in a continuous line. The ends of each segment are then connected to a randomly chosen point. These connecting lines are indicated as s1, s2, etc. The parallels of these lines, s1, s2, etc. are reported and intersected with the previously drawn vertical lines.

On the resulting vertical line R drawn from the intersection of the extension of the first and the last of the polygon lines, will be the location of the center of gravity CG longitudinally. 1 Repeating the operation but now using the horizontal lines, line R' will be determined. The intersection of this line with line R will be the location of the center of gravity, now established in height as well.

Normally, knowing the location of the center of gravity CG in height is not necessary, therefore only the location of the line R is sufficient. The determination of the horizontal line R' graphically is not very precise—all the lines constructed

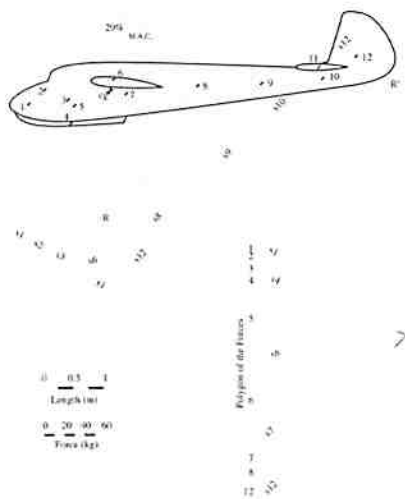

Figure 7-4

horizontally are very close to each other making the process very confusing.

Once the center of gravity has been found, its position may not be what one would have expected. In this case a relocation of weights may be necessary. In our sample case, it is necessary to vary the position of the pilot in relation to the wing. After few changes and with the center of gravity location fixed in the desired location, the project may proceed with the determination of the aircraft shape, dimensions and general arrangements.

40. Side View.

Cockpit. The first consideration is the location of the cockpit. For stability and optimal visibility, the cockpit is located as forward as possible.

For an average pilot (1.70 m), the cockpit will have the following dimensions: From the edge of the seat's shoulder rest to the pedals' rotational: 98-100 cm. Internal minimum width: 54-56 cm. From the edge of the seat to the control column: 45 cm.

In gliders, the seat is ergonomically shaped in order to offer maximum support to the body all the way past the pilot's knees. This is done to diminish leg fatigue, since in most gliders the control pedals are set very high, almost at the same level of the seat.

In the canopy, it is best if the windshield and the side windows are at a small inclination from the vertical axis, otherwise even a light mist may produce a mirroring effect that will reduce visibility. Canopies that are flared to the fuselage with a high degree of inclination are better aerodynamically but offer poor visibility—and are therefore not recommended.

The windshield also should not be close to the pilot's eyes: the optimum distance is approximately 60 cm, which is well over the minimum human focusing distance.

The instrument panel should be at a distance of 60-70 cm from the pilot and lightly inclined forward. Attention should be given to avoid having the panel located too low to prevent interference with the pilot's legs. The seat should be elevated 8-10 cm from the bottom of the fuselage to allow proper clearance for the ailerons and elevator control cables that run under it. The rudder bar cables are run instead in the inner side walls so not to disturb the pilot. The following sketch shows the cockpit arrangements in a standard glider.

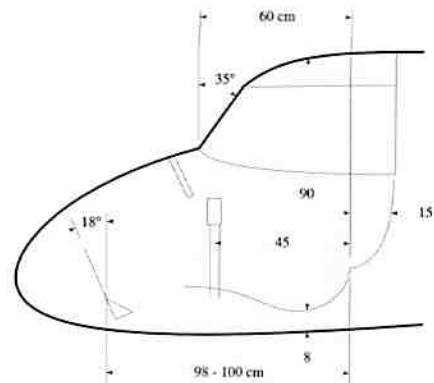

Figure 7-5

There is a space allocated for the parachute, usually 15 cm in thickness and placed behind the headrest. When designing a completely new glider, it is a good practice to first build a prototype of the cockpit. For this a forward section of the fuselage is built, then in it are placed the seat, the control stick, the rudder bar and all the various components. Finally the pilot with parachute will take a seat inside and check for possible interferences, practicality and comfort. If necessary, changes are made until you are satisfied with the design, recorded and transferred to the actual project.

The prototype is constructed with available materials. It does not require an outside aerodynamic shape or need a skinned fuselage. Its function is only to determine the location of the various controls and to finalize the shape and form of the seat for comfort and practical purposes.

Fuselage Shape. Once the various arrangements are established, and it comes the time to design the fuselage shape, there are no specific rules or formulas to allow the designer to get the best fuselage design. It is obvious that from the aerodynamics stand point, curved shapes are more efficient, but they are also more complicated and expensive to build.

As we mentioned before, at this stage in the project the personality of the designer has a lot to do with it. It will be up to him to find the best compromise between the aerodynamic requirements and the available resources.

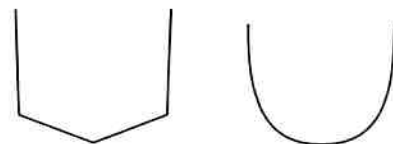

Figure 7-6

Only a few general considerations are mentioned here. It will be up to the designer to decide which will be the best solution. For the forward fuselage section in the cockpit area, it is best to use a uniform width all the way from the shoulder height to the bottom of the seat. If the cross-section is a polygon, it is best if the sides are kept parallel or slightly inclined. If the cross-section is curved, it should be flattened at the bottom.

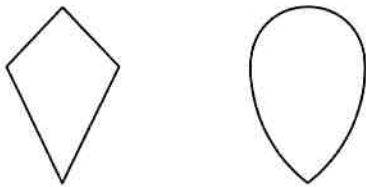

Figure 7-7

This is done in order to locate the seat position as low as possible in the fuselage, therefore reducing the fuselage's overall height. Towards the rear, it is necessary to flatten the fuselage on the sides and create a sharp edge at the bottom. This helps the aircraft's lateral stability since a sharp keel retards and actually opposes lateral slippage.

On occasion, we find that a sharp edge even in the upper portion of the fuselage and the dorsal area, further increases the lateral stability, particularly in flight conditions of high angles of incidence. This design also facilitate the application of plywood skin to the fuselage.

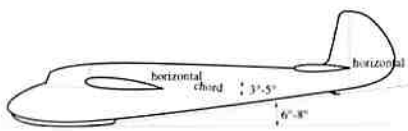

Figure 7-8

In the side view, we have to take into account the planing angle, which is the angle formed by the tangent to the landing carriage when the glider is in flying configuration and the ground. Due to their lower landing speed, the value of the planing angle is not as important for gliders as it would be for powered airplanes, but it is recommended for this angle not to be less than six to eight degrees.

In the side view, the wing chord angle and the stabilizer angle should be defined. The horizontal empennage is usually set at zero degrees to the horizontal plane of the fuselage; for the wing chord that angle is set between three and five degrees.

Wing to Fuselage Connection. The relative position of the wing in respect to the fuselage takes quite an importance in gliders. An interference between these two very important components may increase the total drag up to 15-20% if a bad design choice is made.

An analytical study of the wing-fuselage relationship is not possible. The only way to obtain proper data would be from wind-tunnel testing. But this is always a very laborious and difficult undertaking, especially when dealing with gliders

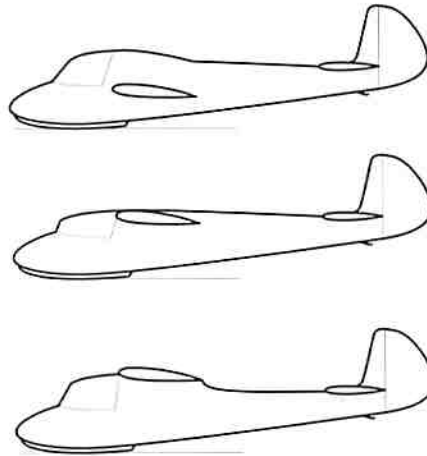

Figure 7-9

The wing position may be: (a) middle wing, (b) high dorsal wing, or (c) high elevated wing (above the fuselage).

In the wing-fuselage connection, the following conditions should be adopted: The angle formed between the wing's upper surface and the fuselage's tangent at the point of intersection should be 90° or higher. The distance between the intersection lines should be constant all the way from the wing leading edge to trailing edge. Understandably, these conditions are difficult to maintain, especially for the middle wing configuration.

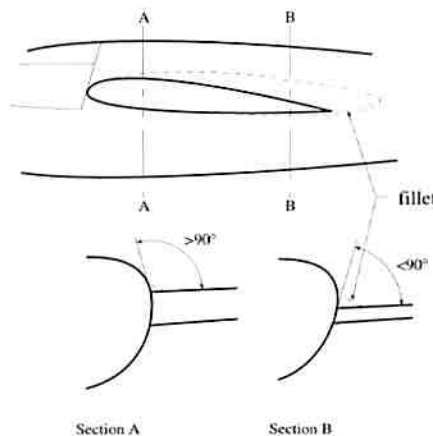

Figure 7-10

The use of a fairing helps the condition by filling those locations where the increased area would reduce the laminar layer's speed. This reduction in speed induces eddies and therefore increases drag. The fairing also assures that the intersection line be in areas of relatively high pressure if at all possible.

It is important to mention that if the wing airfoil is bi-convex or plano-convex (flat bottomed), the connection to the fuselage is quite easy, while in cases of a wing airfoil having deep camber and high lift, it is difficult to obtain a good connection, both constructively and aerodynamically. This is because in a fairly short distance, all the high lift has to be eliminated and reduced to zero at the connection of the wing to the fuselage. It is common to gradually vary the airfoil and reduce the lift as it approaches the fuselage thus facilitating the fairing.

When the wing is high on the fuselage, or above and connected by a dorsal fin (as was often done in the past), the airfoil is left unchanged even if heavily cambered. It is important to note that the fairings used for gliders are different to the ones for powered planes. This is because gliders usually fly in heavy lift conditions, contrary to what happens in regular airplanes.

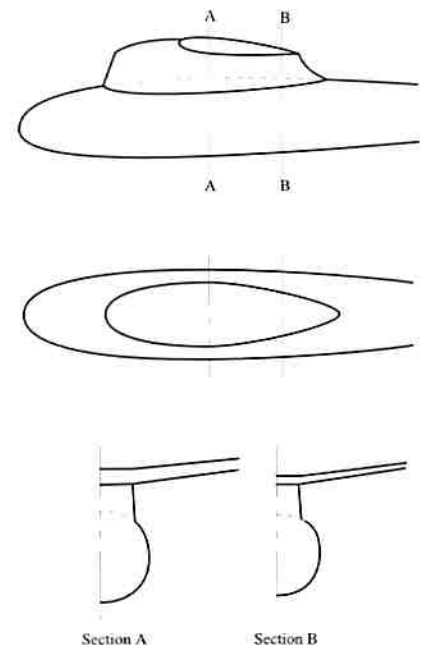

Figure 7-11

From all this, you may conclude that the high-wing configuration is the best solution for wing-fuselage coupling in gliders. The fairing in this case is simple both in design and in construction, consisting generally of a fin with vertical walls that attached at the cockpit.

From Perugia to Oshkosh

By Alfred Scott

Stelio Frati's old company, General Avia, is now in new hands. Frati's atelier in the Milan suburb of Pioltello is closed and production of the F.22 is at the factory in Perugia. I was in Italy in May on vacation, and I drove to Perugia to check on the state of aviation, Frati-style, in Italy today.

I wasn't optimistic, because I've heard for years how the Italians have taxed aviation out of existence. Airplanes are taxed by weight and the annual tax on many designs is greater than their hull value, so most airplanes have long been sold to other countries. When I arrived at the Florence airport, I visited the Aero Club there. There were a few airplanes out on the ramp, and the office was quiet and occupied only by the man who ran the place.

I drove out to the airport in Siena, where we were staying, to find a huge field with three airplanes in residence: a Socata Trinidad, an old French Rallye, and a Cessna 182 for the local parachuting club, which kept the plane busy on weekends. I struck up a conversation with the group at the Aero Club trailer. All knew the Falco, revered Frati and an old mechanic had fond memories of working on Falcos.

I was watching the sky for Andrea Tremolada, who was flying down from Milan for the day. He didn't arrive, and he later called to say he had landed in Parma, and that his ferry tanks, which he was testing, had failed, split open and dumped their contents into the bottom of the Falco. Fortunately, he was carrying water on the flight, and he said that the tanks had failed after four hours of flight and that this was the second time they had failed after four hours in the air. Visions of Andrea and his Falco exploding over the South Atlantic filled my mind and kept me awake all night.

With these pleasant thoughts, I drove to Perugia only to discover that there was no General Avia in Perugia at all. But someone thought it was in a tiny hamlet on the shore of Lake Castiglione. I retraced my steps and found the factory nestled in a sleepy little waterfront town. Everyone was at lunch, and we walked a couple of blocks and found Konrad Lozinski at a café. Konrad was Frati's draftsman in the 70's and had worked on the Falco project then, and because he was from England and thus spoke perfect English, he was my contact

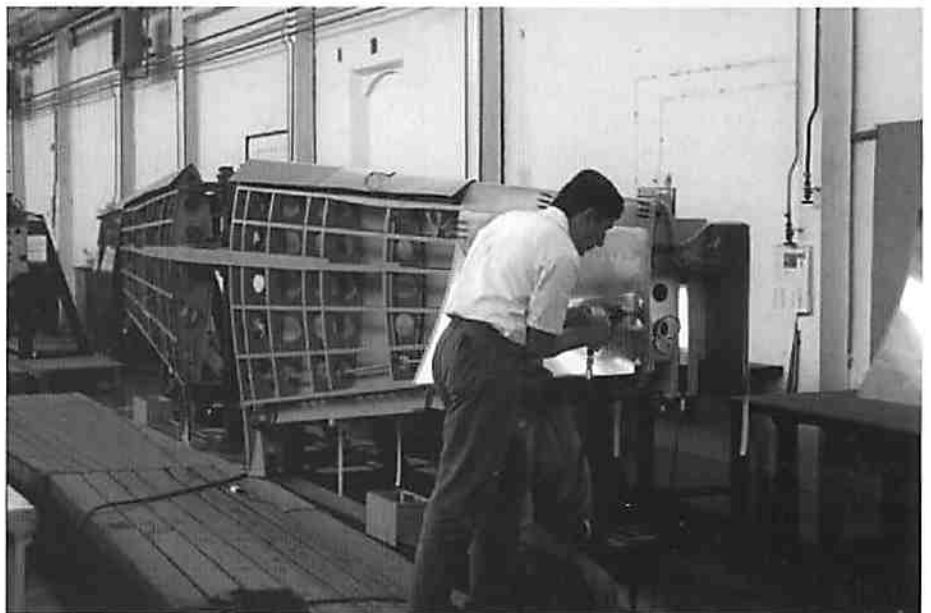

At the General Avia factory in Perugia. Top: Fuselage assembly. Middle: Wing assembly. Above: Engineering office. Konrad Lozinski is third from right.



Top: Fuselage assembly. Middle: Stabilizer assembly.
Above: Konrad Lozinski and the General Avia trophy wall.

back then. He's now in charge of quality control, and he gave me a tour of the plant.

There are about 70 to 80 people working at General Avia now, and the plant is located at a historic old location, once the home of Ambrosini. Many famous designs of the 30's and 40's were produced here, including Stelio Frati's Rondone, a famous canard design, and several jet fighter designs of the second world war.

And it's clear that they are located here because the production equipment was already in place. There is ample factory space, plenty of it unused, and one building houses a pin router, another a hydro-press and heat-treat ovens. Machine-shop equipment is all from the 50's and little has changed in production for the last forty years, except for the PC's which they used for their office and CAD. All of the machining is done in the old, manual way, with nary a programmable lathe or milling machine to be found. And it's fun to see the Falco landing gear retraction motor gearbox, which I designed, as part of the design.

They make almost everything at the plant, including their own exhaust system, probably just because it's simpler to bend up some tubing and weld it together than to deal with suppliers in another country. And the drawings and manuals for the plane are all done on computer, and it's a rare find now to come across a drawing with the famous S Frati signature on it. It's now all in the hands of production, and despite it's racy looks, the F.22 is still a trainer design intended for slower flight and hard landings at the hands of clumsy pilots.

A few days later, back in Siena, Frati's compatriate engineer/designer Ernesto Valtorta, Konrad Lozinski, and I confer on the state of Andrea's ferry tanks. We are all in agreement that the problem is one of vibration in the flat panels of the tanks. Andrea confirmed that the tanks were producing musical sounds as he flew, a sure sign of sympathetic vibrations and impending failure. We all agreed that he needed to stiffen the flat panels of the tank, and further advised Andrea that he should consider putting the tanks through a slosh-and-vibration test.

Andrea agreed and in the next month, he stiffened the tanks and put them through the torture test, if only for 35 minutes, but it was enough to confirm that the tanks had lost their musical talents. And on June 26, Andrea flew to Seville, Spain, in 6

hours and 15 minutes. The next day, Andrea discovered a hole in the bottom of his horizontal stabilizer, but it was in a semi-structural area, and Andrea repaired it in a day.

Throughout the flight, there was tremendous coverage in the press. The Italian newspapers all covered Andrea's flight, as did the radio and television stations in Seville and Recife, Brazil. On Friday, June 30, Andrea flew to Sal Island, Capo Verde, off the coast of Senegal in West Africa. This was the only flight that Andrea flew with full fuel, and he swore he would never do it again. The airplane was very difficult to fly for the first two hours, but flight conditions were good and he landed after 12 hours and 5 minutes of flight. We kept the world apprised of his progress on our website, and during this flight, I got an email from Andrea's office that he was over the Canaries and had just called from the satellite phone he was carrying.

Then on Monday, July 3, Andrea crossed the Atlantic for a flight of 13 hours, 43 minutes and 1,982 miles. It was, he said, the worst flight of his life and he endured violent turbulence and embedded thunderstorms for six hours, at times flying down low over the water, which he could not see, to escape the turbulence.

On landing at Recife, Brazil, he had his first encounter with a Brazilian customs official. It took three hours to get through customs after landing. Andrea's plan was to continue up through the Bahamas, to Florida and then Oshkosh, but it didn't work out that way, and he suspended the flight for 'personal reasons.' Let's just say that Andrea and the customs official did not interact well with each other, and they're not likely to be exchanging Christmas cards either.

Meanwhile, in France, Xavier Beck was making preparations for flying his Falco to Oshkosh by the North Atlantic route, but he was having some minor problems with his engine, and when he read about Andrea's experience over the South Atlantic ("Don't Fly With Me, Donatella", on our website), he cancelled his plans at once.

So our two European stars didn't show up for our birthday party at Oshkosh, but nine other Falcos did and we all had a great time. Bob Hendry showed up in Steve Wilkinson's old Falco. Bob Bready came with Tony Petruccio. Karen and Cecil Rives. Per and Lena Burholm. Jonas and Jon Dovydenas in his bullet-riddled Swing Wing Falco. Richard Clements, with his son, who had just soloed in the Falco. Glyn and Chris Russell. Jim and Jane



Top: Dave and Tamera with their Reserve Grand Champion Falco. Center: Tamera discusses engine options with a future Falco builder. Above: Cecil Rives' Falco.



Top: The Nasons celebrate their award. Center: Richard Clements' Falco. Above: The notorious bullet-riddled Swing Wing Falco of Jonas Dovydenas.

Quinn. And Dave and Tamera Nason in their spectacular red Falco.

The Nasons had just come from the Arlington airshow where they were the Grand Champion Plans-Built, and immediately on arrival, their Falco was the you-gotta-see-this airplane of the show. It is an immaculately built airplane, and television crews and EAA judges were all over the airplane. Indeed, it seems like we did little else but speculate about whether the Nasons would win the Oshkosh Grand Champion award, but the competition is fierce at Oshkosh and they won the Reserve Grand Champion Plans-Built. That's second place and the Nasons were delighted to get it and they went home to Kent, Washington, with smiles on their faces. They were a bit overwhelmed by all the press coverage and attention, as Tamera says "Dave is just a quiet guy who sits in the last pew in church." Maybe that's so, but Dave and Tamera Nason got their 'fifteen minutes of fame' at Oshkosh.

But the most surprised Falco builder was Cecil Rives, who won a Bronze Lindy award, a third-place award that's given to a number of airplanes. Cecil was just beside himself at the news. He didn't even think he was in the running.

There was a lot of attention by television crews on Dave and Cecil's Falcos, so watch the Discovery Channel this year for their coverage of the Oshkosh show as it appears later this year.

(The Swing Wing Falco, by the way, still lives on in the minds of the true believers. One spectator asked a Falco pilot if they were going to install the mod. Even when you tell them it was an April fool's joke, they still believe that the Swing Wing Falco exists. They saw it in *KITPLANES*.)

We were also delighted to have Ian and Juliet Ferguson, and Neil and Gwyn Aitkenhead from Australia. The Falco builder dinners were a great success and we had about 80 people at the big dinner on Friday night. Susan Stinnett, Jack Amos and I arrived complete with Falco birthday T-shirts, mugs and pens. We still have some left and we want all active Falco builders to have a couple of the 'Falco at 45' tee-shirts, so if you didn't get any, let us know your size. And they're also available in the Falco Store on our website.

The next big gathering will be at Oshkosh 2005, for the 50th birthday of the Falco. We may resort to kidnapping to get Stelio Frati there.

Construction Notes

Your mind is the second thing to go. I think, can't remember what the first one was.

In our last FBL, we had details of Richard Clements' canopy seal. The only problem is, Fred Doppelt's memory of it was just a wee bit flawed. So let's revisit the idea again and see if we can't get it right this time.

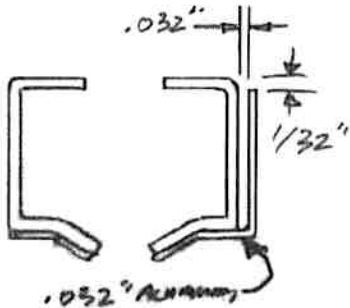

You begin by installing a piece of .032" aluminum, bent to a 90° angle and installed under the canopy track so that it leaves a gap of .032" between this angle and the canopy track. This gap is the slot in which the canopy seal will run. This aluminum angle must be dimpled to fit under the dimple of the canopy track at the screw locations.

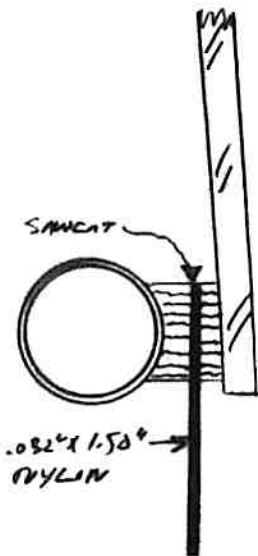

Once the canopy is installed on the canopy frame, you remove the wood strip/spacer between the canopy and the canopy frame, and you bandsaw it into two pieces with a cut right down the middle of the part. Then you sandwich a strip of nylon (.032" x 1.50") in the sawcut and screw it all back together so that the nylon strip projects downward.



To the airport. Al and Steve Dubiak move the Falco out of the garage and onto the flatbed.

Then when you put the canopy on the aircraft, fit this strip into the slot on the outside of the canopy track.

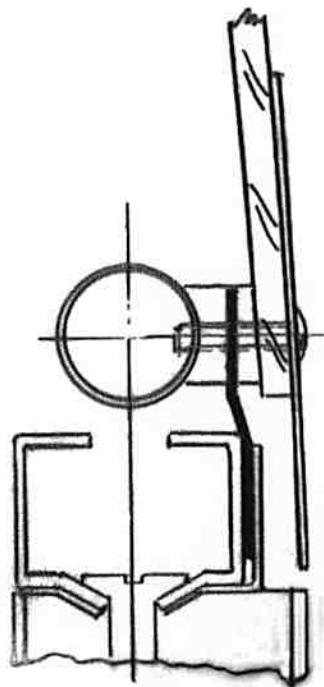

It's a very clever idea and the only negative I can see is the complexity of putting it all

together, but that seems like a very minor problem indeed. Richard Clements says the idea originally came from Kent Paser who installed this on his highly modified Mustang II that achieved astonishing speeds.

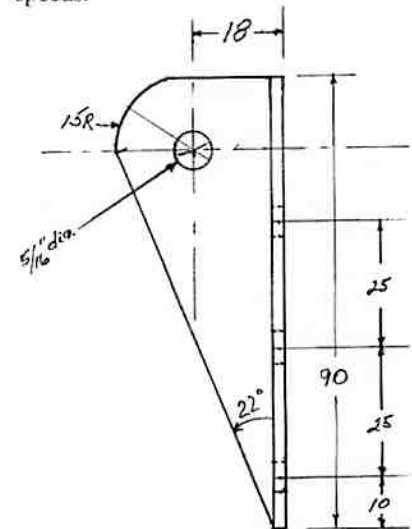

Garry Wilburn sent us a sketch of a minor dimensional change that he made to P/N 805 to avoid mechanical interference with the flap actuator housing. I haven't heard that others have had any difficulty with this, but the change is a small one.

—Alfred Scott

Sawdust

• Just call me 'Sparky'. On the way home from Oshkosh, Bob Bready and Tony Petruccio were IFR at 7,000 between a couple of cells when it got darker, the cockpit lit up with St. Elmo's fire, their hair stood on end and then *bang*. Touched by the hand of God. A spark jumped from the control stick to Bob's left hand—"It felt like you put your hand on a table and someone whaled it with a two-by-four." The panel lit up like a Christmas tree. The alternator went off. The fuel totalizer started flashing, the gas gauges read 'full' for a long time. The GPS lost its position but reset right away. The VORs were fine and no circuit breakers blew. Bob reset the alternator field breaker, it came back on, "and other than the stupid look on our faces, we were off and flying again." On landing, Bob said the only damage was a slight burn mark on the right wing tip lens, so it appears that it was not a direct hit.

• Style setter? We have a report that a Falco being built in Milan, Italy, is planned to be finished out with clear varnish only, so you can see all the wood structure. Hmmm. Interesting idea, but the finished result may not live up to the imagined result—stroll through any nudist colony beach and you are quickly reminded why we all wear clothes.

• Safety Enforcer. Now that you've finished your airplane, you not only have to deal with the FAA, but also with the increasingly rigid requirements of the insurance companies. The latest: Avemco now requires that your test pilot—credentials and experience be damned—must have completed the EAA Flight Advisors course. Which isn't a bad thing at all.

Goings On at Sequoia Aircraft

Gosh, we don't have a lot of space left in this newsletter, so I'll keep it short! I've been busy much of this spring with a must-do project with my programming, but I have that largely finished now and I've been putting a lot of time on the Falco recently.

So busy, in fact, that we didn't get a June newsletter out, and sometimes I wonder if we should move everything to the website—but there are a lot of you out there who live for the Falco Builder Letter.

I have been making a lot of additions to our website, and I would urge all of you to keep

June/September 2000

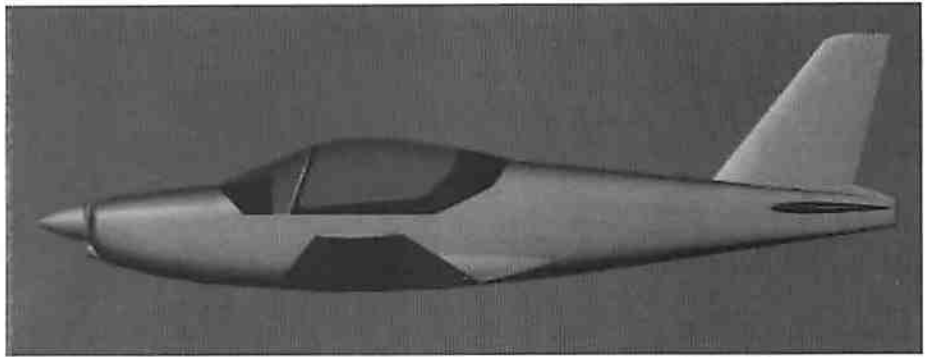

Top: Stelio Frati moves to composites. At Oshkosh, the Italian company Sky Arrow was handing out illustrations of Frati's new four-place design. Above: The Corporate Disgrace never looked so good as in this model made by Luigi and Davide Aldini.

an eye on it for the next few months. I expect to add a great deal to the Falco Store, and to offer people a better look at what is included in the kits, with photos or drawings of the various components. I also have a backlog of articles on the Falco, which I have been adding to the website.

We are planning to produce a series of posters on the Falco, with perhaps a new one every year or so. The first one will feature the Falco paint schemes and we should have that out in a month or so. Active Falco builders (i.e. those of you who get the Falco Builder Letter) will receive one free, and we will have additional copies available in the Falco Store on our website. We just want to keep you pumped up and excited as you build your Falcos. And we would be very interested in any ideas for future posters that you may have.

—Alfred Scott

Calendar of Events

West Coast Falco Fly-In. September 7-10, 2000 at Crest Airpart, Kent, Washington. Contact: Dave & Tamera Nason, 17618 S.E. 303rd St. Kent, WA 98042, (253) 631-0191

Susan's Corner

Oshkosh was a smashing success this year, and I do believe a grand time was had by all. It's always a treat for me to meet with you guys that I'm always on the phone with. There were a lot of new faces this year, but a lot of old familiar ones as well.

We're gearing up to begin a new batch of main spars, among other things (miscellaneous other spars and some of the fuselage frames that we're running short of), so it looks like Fall in Virginia will find the sawdust flying out in the warehouse.

Kit sales have continued to be steady and already I'm making a list of parts that need to be made again. I have some parts from before that still are in the works and as soon as I have them in stock I'll get them to those of you who are waiting for them.

Space is short, so that's it for now. Keep sending us pictures and reports on your progress. And be on the lookout for those posters. I think they're gonna look sweet, and I also think it's a terrific idea (only because it was my idea). You're really gonna love 'em.—Susan Stinnett

Mailbox

I have a friend, Michael Maniatis, who is a pretty active homebuilder, especially considering the fact that he lives—and builds—in Manhattan. He owns a Tiger Moth and some other kind of Moth, and several years ago built a replica of a DH racer in his Manhattan studio, which got quite a bit of coverage in *Sport Aviation*.

He's now building another rare DH replica, and has run into a wood problem. He installed the fuselage skins last winter, when the wood was super-dry—steam-heated New York apartment, etc.—and then immediately painted the interior of the cockpit with nice Brit "cockpit green" but did nothing to the exterior.

Now that it's an incredibly humid summer, the skins are warping terribly.

His question: If he somehow manages to get the plywood dry again, using dehumidifiers, hair dryers, bonfires, whatever, and then coats the exterior of the panels with whatever he's going to use, assumedly some kind of polyurethane, will that seal and stabilize the wood so that it will no longer absorb moisture, or does the moisture get in there no matter what you do?

In other words, is his basic problem that he put the wood on too dry in the first place and there's no way around that, or can his warpage be corrected and stabilized? Whaddya think?

Michael is, incidentally, a very well-know fabricator of all sorts of models and devices for use in photography, TV and films. His most recent gig was making a prosthesis for Britney Spears' appearance as the host of Saturday Night Live several weeks ago. The device allowed Michael to radio-control her breasts, from a position off-stage, so that during a number, the subject of which was whether or not her tits were real, they began to mysterious move around with a life of their own.

Knew you'd appreciate that. There may be a Falco Builder Letter item in it... the skill you develop as a homebuilder...

Steve Wilkinson
Cornwall-on-Hudson
New York

Michael's problems with his airplane are permanent, in that he has assembled components of wildly different moisture contents. There is no cure for this except to remove the skins and start over with components that are all stabilized to roughly the same moisture content.



André Bauby's Falco in France.

I had this happen with a 12-string guitar I built some years ago, and the crack in the top is still there and can only be patched. The problem with musical instruments is so severe that Martin Guitars has sensors all over the factory to pick up the humidity and if it gets out of range, then alarms go off in the office.—Scott

Construction of the Falco took about five years. I started building the spar with Carolina pine, spruce and Douglas Fir being unavailable in France. I built the wings, the fuselage, and I glued on the wings—a few problems to make the skin flush.

I then made all the metal parts, landing gear, engine frame... and the epoxy fiberglass parts: fairings, cowlings... and even the wooden propeller. Then I made a wooden and fiberglass mold for the canopy and had the canopy made by an industrial firm. The plane has 15 hours flying time and has just been authorized.

The engine is a 180 hp with fuel injection. Cruising speed is about 300 kmh with a fixed pitch prop, which would be worth a variable pitch prop.

The inside is lined with leather. The plane weighs about 508 kg.

André Bauby
Cadalen
France

Just a short note to introduce myself and inform you that my partner Bill Jones and myself have recently acquired the Sequoia Falco C-CWAG built by the late Charles Wagner. Mr. Wagner, as you are possibly aware, had been ill prior to the completion of the project but thankfully did have the opportunity to at least enjoy the aircraft, albeit if only for a short time, prior to his untimely death. Bill and myself fly from the Leicestershire Aero Club, and this is where the aircraft will be based. We have another Falco on the airfield G-OCAD built by David Norwill, Clive Garrad and Gordon Blunt, and what a beautiful example it is.

For the past two weeks we have been flying the aircraft, and we are over the moon (British expression for being very happy) with the looks and handling of the aircraft. Charles did a good job with the structure,

but due to the understandable rush at the end of the project the paint job isn't the best and needs some work which we will tackle at the end of this flying season.

We have decided to leave the registration of G-CWAG in place as a flying memorial to the hard work and dedication to the project over the last twelve years by Charles Wagner.

*Ivan R. Court
Saddington, Leicestershire
England*

I must say I echo the sentiments of the guy in the newsletter who said he hopes that Alfred the Great finds it difficult to find someone to take over Sequoia. He's a hell of a guy.

*Bob Dell
Melton Mowbray
Leicestershire
England*

When I built my Falco, I made molds for all the small fairings shown in Drawing G20, plus fairings for the trim pushrod and rudder cables. I've been passing these around to builders to use for their fairings. Although I made them to fit my bird, so far I've gotten no complaints from the others (Al Dubiak, Martin Pierce, Mike Wiebe and Wayne Rampley), so they apparently fit other Falcos pretty well.

I'll be glad to loan them to other Falco builders if they'll pay for the shipping (about \$20). Anyone interested can call me at (405) 721-8428 or e-mail me at jimpetty@home.com.

I didn't make them for a production run, so I don't know how long they'll last. However they seem to be holding up pretty well so far. I still have the master models, so I can make more molds if need be.

I read Cecil Rives' article about installing an S-TEC autopilot with interest—I've just purchased an S-TEC System 50 for my bird, and will be installing it in late June. I've also gotten a Garmin GPS 400 receiver, which I'm thinking about mounting on top of the panel like a heads-up display. I'll let you know how it goes.

This past February, when I did my annual, I installed EII manifold pressure gauge, EII tachometer and added a fuel pressure transducer to my EII fuel pressure gauge. It's taking a bit of getting used to, but I like the higher accuracy they give.

I also got my prop overhauled since it had passed 500 hours. I had it done at AAR

Oklahoma here in OKC. Great service—they started tearing it down before I left the shop, and had the overhaul completed a week later. Cost was \$1,364—about the same as Hartzell (who wanted over two months to do it).

I've just passed 525 hours on my Falco. I'm averaging 100 hours per year.

*Jim Petty
Oklahoma City
Oklahoma*

I am delighted to count myself amongst the privileged mortals that own the superb Falco! My wife and I recently purchased G-FALC from Peter Hunter after he had owned the aircraft for 15 years. Please amend your records accordingly and be assured of the warmest of welcomes to any followers of the cult that find themselves at our base—Oxford (Kidlington) airport—on their travels.

*Jeremy & Paula Cooke
Hill Court, Tackley,
Oxon, OX5 3AE,
England.*

I have finished my Falco as I finally got the magneto fixed, and it is running fine. I anticipate doing the taxi tests tomorrow to check the controls for authority. Then I will call the FAA for the final inspection.

That could take some time as the FAA moves in slow ways. I feel there will be a fairly quick inspection by them but a rather involved one by my friends Ray and Cecil so I anticipate the first flight will be sometime in August after Oshkosh, and I will let you know a more exact date when I have it.

*Bill Russell
Houston, Texas*

Bill Russell's Falco is almost ready to fly.



The plans finally arrived at 1:30 pm today, Saturday 1st July, after I gave the local courier company a bollocking last night. They delivered them Friday, but took them away again as I wasn't home, despite my explicit instructions to the contrary. In my view stupid people should be culled to make more space for the rest of us. I think it's called "adding chlorine to the human gene pool".

Well... I've spent about three hours pre-viewing them and, as you would expect, I am now in information overload mode!

*Rob Phillis
Perth
Western Australia*

Just a quick note on progress to date. I built the fuselage first then the wing, both were skinned then the wing mated to the fuselage. I did it this way because of my severe shortage of space. It was easier to build the fuselage, get it out of the way, then build the wing. I thought I was going to have to rent a shop for a week or so to put them together, but I had enough room in my shop by putting the fuselage cross-ways and the fuselage length-ways. No room to walk from one end of the shop to the other, had to crawl under the fuselage. Hard work.

I had a bit of scare when the gluing of the wing to the fuselage was complete and lightly clamped with only two clamps. The triangulation, which had been right on, was out by about 3/8". Too late to change anything so I applied the rest of the clamps and cinched them up. I checked after this was done and found it to be right bang on.

All that cussing and self condemnation for nothing!

I don't know how others are checking levels, but I used a 1/4" ID neoprene tube filled with water, food coloring and a few drops of liquid detergent. The food color to make it easier to see and the detergent to reduce the surface tension of the water so it doesn't curve up the side of the tube thus giving a straighter leveling line. I select two places on the aircraft that should be level (water line 0 front-to-rear, for example) and place the tube between these two places and bring the aircraft to the water line in the tube at both ends. Care should be taken that there are no air bubbles in the tube. This can cause great panic, I know, I've been there!

The aircraft is now back in two pieces, this time however it's the wing and forward fuselage and the tail cone forming the two sections. Skinning is all but complete including the control surfaces. The only skinning left to do is the fuselage under the wing and a couple of panels at the front and rear of the fuselage that have been left open to give better access for the installation of hardware.

*Gordon Cook
Surrey, British Columbia
Canada*

I still have not sold the metal building I spoke to you about a few years ago, so as an economic necessity, I have to proceed as far as possible on the aft section of the fuselage, until I sell the damned building and can order the nose gear and engine mount kits.

I have the 10 x 20 stringers installed, as well as the shoulder belt support strips, the #6 diagonal frame and the mountings for the inverted gas tank. All longerons except the lower side longerons are installed, though left unglued at fuselage frame No. 1. Now I am working on the lower side longerons. I am making them of yellow poplar, since I have a good supply of that specie. Early on, I became aware that poplar is somewhat stiffer than spruce, and I knew that the twist bend requirements on this longeron would be challenging. A week or so ago, I had a brainstorm, built on the premise 'divide and conquer'. So I'm laminating the two lower side longerons of 3mm thick stock. It's working well, so I pass it along for others to consider.

*Garry Wilburn
Clarksville
Virginia*

Just signed the lease for some hangar space, a 19' x 20' space that should be fine for the final assembly. Engine should be here second week of July.



Tony Petruccio checks the gear retraction of John Devoe's 44 Fox.

I think that the panel turned out well, I've added a small drawer for maps and fuses. The interior is now finished and will be moving the tail to the hangar in the next couple of weeks. New windshield fitted and will install permanently after we install the panel. Canopy is fitted and the patterns for the canopy skirts are somewhat finished.

Will start the painting prep prior to the arrival of the engine. The plan is to paint the wing section then transport to airport, bring the tail back and paint that.

*Bob Brantley
Santa Barbara
California*

N72GR has 70 hours on it now, and I'm really enjoying the ride. We've had a minimum amount of problems with the airplane. I still have radio difficulties regarding excessive noise and inability to communicate with approach control frequencies although the unicom frequencies work fine. The avionics shop has not been able to correct these problems (yet).

The right aileron is slightly out of adjustment which causes the ball in the turn and bank to show slightly right of center. This has not affected the flying, but it does have a small negative effect on air speed. To correct the problem, the connector at the turnbuckle needs to be ground off by about 1/4" then the cable should be re-adjusted. I'm having so much fun flying the plane, I haven't taken time to make the adjustment.

The airplane has been through a complete set of Falco aerobatics including three spins

to the left and three to the right. It has also been flutter tested to 200 knots, which makes me feel better when I'm flying.

Words cannot adequately express the joy I feel every time I leave the ground in the Falco. It's a dream come true. My heart sings!

*Glyn Russell
Hartselle
Alabama*

If the ball is not in the center, you can correct this with an elevator tab or an aileron tab. Adjusting the turnbuckles has zero effect. Repeat ZERO. All you're doing there is adjusting the position of the control stick. It's a common misunderstanding.—Scotti



Neil Aitkenhead with a wheel well laminate.